

SWING CHECK VALVE

M&J VALVE®



ABOUT M&J VALVE

As a Celeros Flow Technology brand, M&J Valve is a key technology partner to companies across the globe that are involved in the storage, transportation, production or processing of gases and liquids. Founded in 1962, the M&J brand has an established history of product innovation and provides a wide variety of flow control solutions to the liquid, geothermal and gas markets.

The extensive M&J range includes control valves, gate valves, check valves, diverter valves and surge valves, plus flow loops for valve testing purposes. M&J valves make use of an array of different shut-off mechanisms (slab, piston, swing, rotary and axial) to satisfy a wide range of application characteristics. They are suitable for incorporation into overland and subsea pipelines, storage facilities, offshore platforms and pumping stations.

Thanks to high grade engineering and quality of manufacture, M&J valves can deal with a broad range of different pressure conditions and a large number of cycles, as well as offering ease of use, ongoing reliable operation and prolonged seal life. Comprehensive aftermarket services, accessible through the global network of Celeros Flow Technology service centers, help customers to maintain lifecycle performance and optimize return on investment.

AN INEXPENSIVE LOW MAINTENANCE BACK FLOW PREVENTION SOLUTION

In cross country pipelines, at river crossings, subsea tie-ins and on offshore platforms, the prevention of back flow protects your equipment, the environment and saves lives. These are only a few of the applications where the M&J swing check valve prevents back flow. Its proven, reliable design meets the demands of a wide range of both surface and subsea flow control applications in oil and gas transmission, distributor, production, and a wide range of industrial services.

SIMPLE – COST EFFECTIVE

The M&J swing check valve's continuous operation ensures reliable protection. Without the need for an outside power source, the M&J swing check valve is an inexpensive, low maintenance solution to prevent back flow.

FOR STANDARD OR CRITICAL APPLICATIONS

M&J offers swing check valves with a wide range of convenience, performance and safety options. Full opening designs minimize pressure drop across the valve and permit passage of intelligent pigs, scraper pigs and spheres. For high temperature service metal to metal seat seals and ring joint cover seals are standard.

For turbulent flow conditions, M&J swing check valves are offered with slam retarders. For subsea, custom engineered swing check valves are built to meet the most demanding customer specifications, testing and operational requirements. In short – if there is a need for a positive shut off of back flow, M&J can engineer and manufacture a swing check valve solution to meet the customers requirements.

CONFORMANCE TO THE HIGHEST STANDARDS

M&J Valves were designed, manufactured and tested in a plant whose Quality Management System was certified as being in conformity with API-Q1 and ISO 9001:2015 by a certification body.

M&J swing check valves can be manufactured to meet one or more of the following standards.

- ANSI B 16.5 – flanges and flanged fittings
- ANSI B 16.34 – steel valve specifications
- API – 6D – pipeline valve specifications
- ASME Section VIII – boiler and pressure vessels
- DOT Parts – 191, 192 and 95 Title 49 – pipeline standards
- NACE MR-01-75 (Latest edition) – corrosive materials standard

POSITIVE BACK FLOW PREVENTION

The clapper is the only moving part in a M&J swing check valve. During normal flow the clapper swings up allowing free forward flow. When pressure is lost across the valve, the clapper falls and creates a barrier to backflow in a fraction of a second. The higher the backflow pressure the tighter the seal.

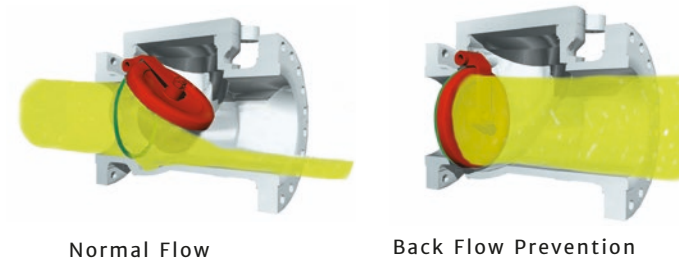

TESTED FOR SAFETY AND PERFORMANCE

M&J Valve subjects each swing check valve to shell and seat tests in accordance with applicable standards. Customer specified testing and non-destructive exams are available on request.

PERFORMANCE OPTIONS AVAILABLE

M&J pipeline check valves with removable seats are available upon request. Most of these requests are for applications that permit seat monitoring or where a defined maintenance program or extremely corrosive or erosive service is in place.

M&J swing check valves may include one or more of these options:

- Accessory mounting
- Body Drain
- Extended shaft with:
 - Counterweight
 - Position indicator
 - Proximity switch
 - Slam retarder
 - Lock open
- Emergency shutdown systems:
 - Pressure actuated
 - Solenoid actuated
 - Temperature actuated



TYPICAL APPLICATIONS

Oil, Gas, Liquid Products & Secondary Recovery

Mainline Block Valves

Tank and Station Valves

Block & Bleed Valves

Manifold Valves

Launcher/Receiver Trap Valves

Meter Bypass Valves

Emergency Shutdown Valves

Hot Tap Valves



WIDE RANGE OF MATERIALS & SIZE AVAILABILITY

Standard M&J swing check valves are available in sizes 2" thru 36"; ANSI class 150 thru 1500 are available in flanged and/or weld end configuration.

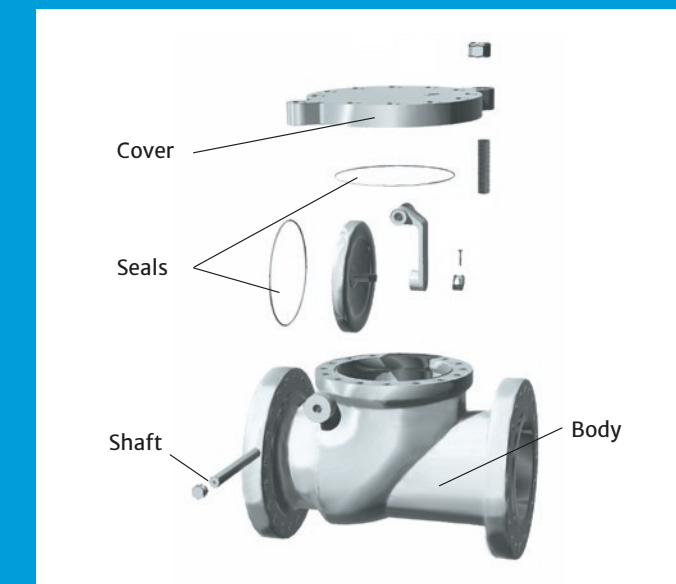

In addition to carbon steel, M&J Valve can fulfill alloy and stainless steel requirements. Engineering assistance in recommending materials for special service requirements is also available.

- | SPEED
- | EXCELLENCE
- | PARTNERSHIP



ABOUT M&J VALVE

As a Celeros Flow Technology brand, M&J Valve is a key technology partner to companies across the globe that are involved in the storage, transportation, production or processing of gases and liquids. Founded in 1962, the M&J brand has an established history of product innovation and provides a wide variety of flow control solutions to the liquid, geothermal and gas markets.

The extensive M&J range includes control valves, gate valves, check valves, diverter valves and surge valves, plus flow loops for valve testing purposes. M&J valves make use of an array of different shut-off mechanisms (slab, piston, swing, rotary and axial) to satisfy a wide range of application characteristics. They are suitable for incorporation into overland and subsea pipelines, storage facilities, offshore platforms and pumping stations.

Thanks to high grade engineering and quality of manufacture, M&J valves can deal with a broad range of different pressure conditions and a large number of cycles, as well as offering ease of use, ongoing reliable operations and prolonged seal life. Comprehensive aftermarket services, accessible through the global network of Celeros Flow Technology service centers, help customers to maintain lifecycle performance and optimize return on investment.

AMERICAS

Houston, USA P: +1 800 231 3690 or +1 281 469 0550 E: mj.valve@celerosft.com

Jenks, OK, USA P: +1 918 701 2660 E: mj.valve@celerosft.com

ASIA

Shanghai, China E: mj.valve@celerosft.com

MIDDLE EAST

Abu Dhabi, UAE P: +971 2 408 1900 E: mj.valve@celerosft.com

Dubai, UAE P: +971 4 5289 555 E: mj.valve@celerosft.com

Celeros Flow Technology reserves the right to incorporate our latest design and material changes without notice or obligations. Design features, materials of construction and dimensional data, as described in this bulletin, are provided for your information only and should not be relied upon unless confirmed in writing. Please contact your local sales representative for product availability in your region. For more information visit www.celerosft.com.